



Mini Submersible / Fountain / Pond Pump



Item 68372



Item 68389



Item 68393



Item 68395



Item 68396

⚠ WARNING

Read this material before using this product. Failure to do so can result in serious injury. **SAVE THIS MANUAL.**

When unpacking, make sure that the product is intact and undamaged. If any parts are missing or broken, please call 1-800-444-3353 as soon as possible.

Visit our website at: <http://www.harborfreight.com>

Before start-up:

The pump can be connected to any shock-proof plug which has been installed according to regulations. The plug must have a supply voltage of 120 V~ at 60 Hz.

CAUTION:

This pump has been evaluated for use with clear water only. Do not use in or around swimming pools.

WARNING:

IMPORTANT! For your own safety – before starting to run the pump, please have the following items checked by an expert:

1. To reduce the risk of electric shock, use only on portable self-contained fountains no larger than 5 feet in any dimension.
2. Risk of electric shock – This pump is supplied with a grounding conductor and grounding-type attachment plug. To reduce the risk of electric shock, connect only to a properly grounded, grounding-type receptacle.
3. Risk of electric shock – This pump has not been investigated for use in swimming pool areas.
4. The electrical connections must be protected from moisture.
5. If there is danger of flooding, the electrical connections must be taken to higher ground.
6. Circulation of caustic fluids, as well as the circulation of abrasive materials, must be avoided at all costs.

7. The pump must be protected from frost.
8. The pump must be protected from running dry.
9. Access by children should also be prevented with appropriate measures.
10. To avoid the possibility of the pump plug or receptacle getting wet, position pump to one side of a wall mounted receptacle to prevent water from dripping onto the receptacle or plug. The user should arrange a “drip loop” in the cord connecting the pump to a receptacle. The “drip loop” is that part of the cord below the level of the receptacle, or the connector if an extension cord is used, to prevent water traveling along the cord and coming in contact with the receptacle.
11. **WARNING:** Handling the Power Cord on this product will expose you to lead, a chemical known to the State of California to cause cancer, and birth defects or other reproductive harm. Wash hands after handling. (California Health & Safety Code § 25249.5, *et seq.*)
12. The warnings, precautions, and instructions discussed in this instruction manual cannot cover all possible conditions and situations that may occur. It must be understood by the operator that common sense and caution are factors which cannot be built into this product, but must be supplied by the operator.

Fluid Type

The Pump is designed for use with salt and fresh water with a maximum temperature of 77° F (25°C). Do not use in hot water. Do not use the pump for other fluids, especially not fuels, cleaning fluids, or other chemical products.

Specifications

Description	Item # 68372	Item # 68389	Item # 68393	Item # 68395	Item # 68396
Electrical Input	120 V~ / 60 Hz				
Amps	.195 A	.07 A	.58 A	.23 A	.14 A
Max. Flow Rate	200 GPH	92 GPH	620 GPH	264 GPH	158 GPH
Max. Head Lift	4.6 FT.	2.3 FT.	11.5 FT.	4.6 FT.	3.6 FT.
Outlet Size	.53 IN.	.5 IN.	.56 IN.	.5 IN.	.56 IN.
Cord Length	6 FT.				



Save This Manual

Keep this manual for the safety warnings and precautions, assembly, operating, inspection, maintenance and cleaning procedures. Write the product's serial number in the back of the manual near the assembly diagram (or month and year of purchase if product has no number). Keep this manual and the receipt in a safe and dry place for future reference.

Installation

Please note!

1. The pump is designed to be used in aquariums/water features.
2. The pump must be placed on the bottom of the aquarium/water feature. To ensure that the pump works properly, keep the bottom of the aquarium/water feature free from sludge and dirt of all kinds.
3. For proper cooling, only operate pump when it is completely submerged. See the Specifications Chart for the maximum lift for your particular pump.
4. **NOTE:** Pumps models **68393** and **68395** each come with their own extension set. To attached extension to the pump, thread selected extension outlet to top of extension. Then thread bottom of extension to extension valve. Use adapter to connect assembled extension to water outlet at top of pump housing.

Power Supply

1. The pump is equipped with a shock-proof plug according to regulations. The pump is designed to be connected to 120 V~, 60 Hz GFCI-protected safety socket.
2. Make sure that the socket is sufficiently secured and is in excellent condition.

3. When the plug is inserted into the socket the pump will operate.

WARNING! If the power cord or plug is damaged, do not use the pump. The power cord or plug may only be repaired by a certified electrician.

Operation

1. Set the pump on a level spot in the aquarium/water feature. The suction cups must be in contact with the aquarium/fountain floor or a smooth platform.

NOTE: Do not plug in pump yet.

CAUTION: Verify pump is adequately supported. If you use an additional hose and in-line filter (not included), do not use it or the connecting tube to support the pump.

2. Once the pump is fully submerged and adequately supported, shift the regulator to adjust flow rate.
3. **NOTE:** After reading these instructions, consider the following points before starting the pump:
 - a. Verify that the pump rests on the floor of the shaft, if it is not suspended by the power cord.
 - b. Verify that the delivery pipe is properly connected.
 - c. Verify that the electrical connection is 120 V~, 60 Hz.
 - d. Verify that the electrical socket is in good condition.
 - e. Verify that water and moisture cannot get near the power supply socket.
 - f. Verify that the pump is installed so as to prevent running dry.
4. Once you've verified that the pump has a proper setup, dry your hands and plug the power cord into the electrical outlet to begin pump operation.

Quarterly Maintenance

The below maintenance should be performed at least once every 3 months under optimal conditions. If pump starts to sound abnormal, unplug it and check the Impeller by doing the following:

WARNING

TO PREVENT SERIOUS INJURY FROM ACCIDENTAL OPERATION:
Unplug the Pump from its electrical outlet before performing any inspection, maintenance, or cleaning procedures.

If the pump is moved to a different aquarium or water feature, flush it out with clean water and dry before setting up in new water feature.

If cord is damaged, it must be replaced by a qualified technician.

1. Remove the front cover and filter/regulator (depending on particular pump).
2. Gently pull out the Impeller from the pump body.
3. Rinse the Impeller assembly with clean water. Use an old toothbrush to remove any debris.
4. To prevent damage, do not rest the pump on the impeller or pry against the impeller
5. Once, clean reassemble Pump.
6. **NOTE: Make sure the power cord is unplugged before performing any maintenance or cleaning.**

Troubleshooting

Problem	Possible Causes	Possible Solutions
Pump runs, but will not deliver any water.	<ol style="list-style-type: none"> 1. Filter and/or impeller clogged. 2. When starting, the pump water height is beyond the head lift. 3. Low line voltage. 4. Optional connecting tube is improperly installed. 	<ol style="list-style-type: none"> 1. Remove filter. Clean out dirt and debris from filter and impeller. Then replace Filter. 2. Check specifications chart and verify pump is not exceeding head lift. 3. Consult an electrician. 4. Remove and examine check valve.
Pump won't start or run.	<ol style="list-style-type: none"> 1. Check power connections and circuits/fuses. 2. Filter and/or impeller clogged 3. Defective motor. 	<ol style="list-style-type: none"> 1. Consult an electrician. 2. Remove filter. Clean out dirt and debris from filter and impeller. Then replace filter. 3. Have a qualified service technician repair or replace.
Excessive noise or vibration.	<ol style="list-style-type: none"> 1. Worn bearings. 2. Debris in impeller. 	<ol style="list-style-type: none"> 1. Have a qualified service technician repair or replace. 2. Remove filter. Clean impeller. Then replace filter.
Pump starts and stops too frequently.	<ol style="list-style-type: none"> 1. Water temperature too high. 2. Pump placed in fluid that is not clear fresh or salt water. 	<ol style="list-style-type: none"> 1. Do not exceed 77° Fahrenheit. 2. Install pump in clear fresh or salt water aquarium/water feature.



Follow all safety precautions whenever diagnosing or servicing the tool. Disconnect power supply before service.

PLEASE READ THE FOLLOWING CAREFULLY

THE MANUFACTURER AND/OR DISTRIBUTOR HAS PROVIDED THE PARTS LIST AND ASSEMBLY DIAGRAM IN THIS MANUAL AS A REFERENCE TOOL ONLY. NEITHER THE MANUFACTURER OR DISTRIBUTOR MAKES ANY REPRESENTATION OR WARRANTY OF ANY KIND TO THE BUYER THAT HE OR SHE IS QUALIFIED TO MAKE ANY REPAIRS TO THE PRODUCT, OR THAT HE OR SHE IS QUALIFIED TO REPLACE ANY PARTS OF THE PRODUCT. IN FACT, THE MANUFACTURER AND/OR DISTRIBUTOR EXPRESSLY STATES THAT ALL REPAIRS AND PARTS REPLACEMENTS SHOULD BE UNDERTAKEN BY CERTIFIED AND LICENSED TECHNICIANS, AND NOT BY THE BUYER. THE BUYER ASSUMES ALL RISK AND LIABILITY ARISING OUT OF HIS OR HER REPAIRS TO THE ORIGINAL PRODUCT OR REPLACEMENT PARTS THERETO, OR ARISING OUT OF HIS OR HER INSTALLATION OF REPLACEMENT PARTS THERETO.

Parts List

Part	Description	Qty
1	Regulator	1
2	Front Cover	1
3	Water Seating	4
4	Impeller Head	1
5	Impeller	1
6	Impeller Shaft	1
7	Sealing Ring	1
8	Shaft Cover	1
9	Suction Cup	4

Part	Description	Qty
10	Water Outlet	1
11	Pump Housing	1
12	Motor	2
13	Magnet Wire	2
14	Cord Clamp	1
15	String Block	1
16	Power Cord	1
17	Back Cover	1
18	Plug	1

Assembly Diagram

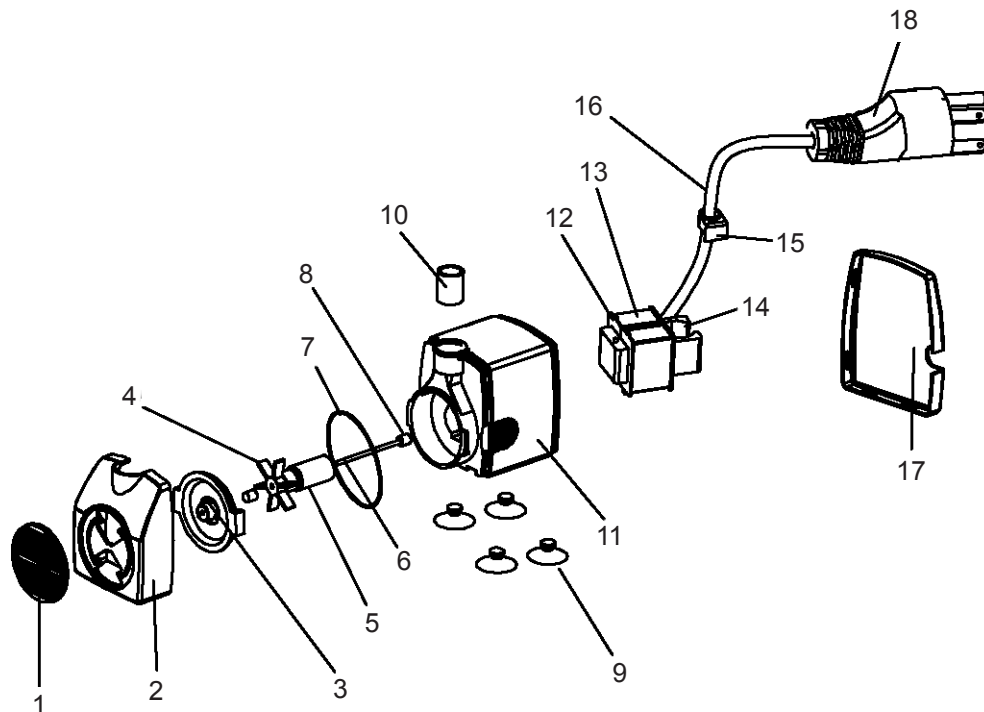

Record Product's Serial Number Here: _____

Note: If product has no serial number, record month and year of purchase instead.

Note: Some parts are listed and shown for illustration purposes only, and are not available individually as replacement parts.

68393 Parts List and Assembly Diagram

Parts List

Part	Description	Qty
1	Front Cover	1
2	Filter	1
3	Water Seating	1
4	Impeller Head	1
5	Impeller	1
6	Impeller Shaft	1
7	Suction Cups	4
8	Water Outlet	1
9	Pump Body	1
10	Motor	2
11	Magnet Wire	2

Part	Description	Qty
12	Power Cord	1
13	Cord Clamp	1
14	String Block	1
15	Back Cover	1
16	Plug	1
17	Grounded Terminal	1
18	Frame	1
19	Sealing Ring	1
20	Shaft Cover	1
21	Sealing Ring	1

Assembly Diagram

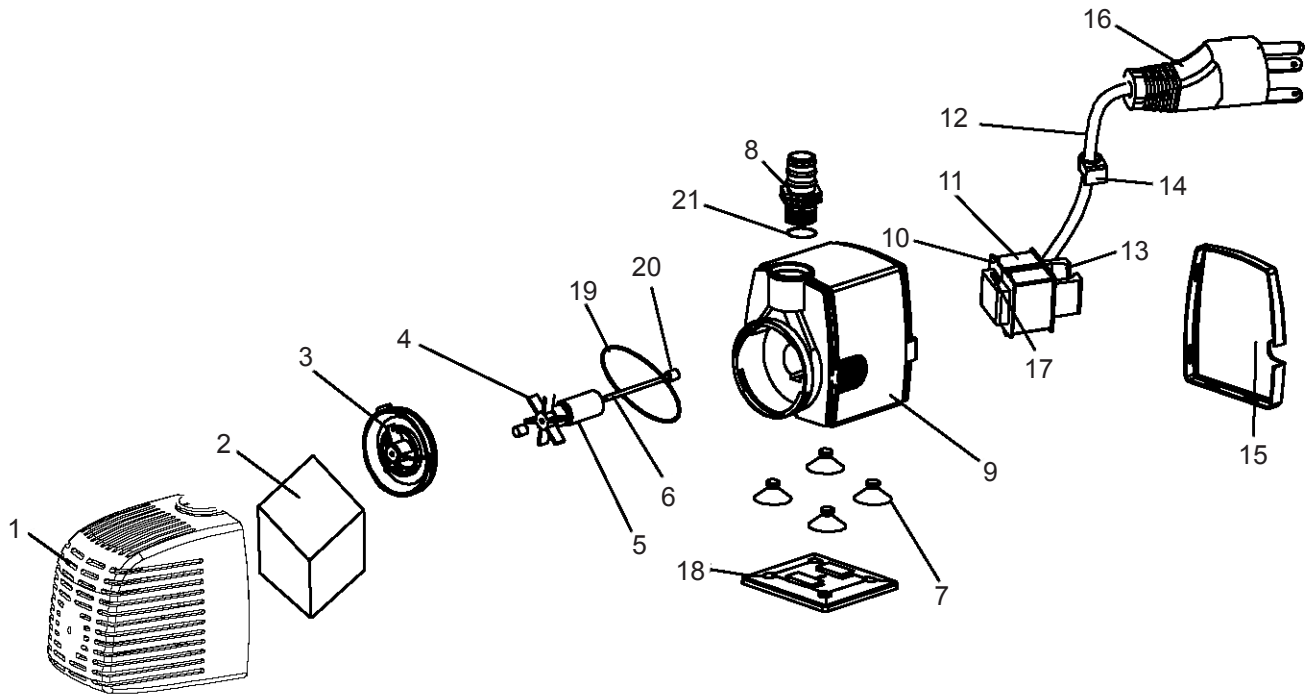

68393 Parts List and Assembly Diagram

Parts List

Part	Description	Qty
1A	Extension	1
2A	Star Outlet	1
3A	Foam Outlet	1
4A	Bell Outlet	1
5A	Top Connector	1
6A	Left Adjustment Lever	1

Part	Description	Qty
7A	Right Adjustment Lever	1
8A	Extension Valve	1
9A	Main Outlet	1
10A	Lower Connector	1
11A	Adapter	1

Assembly Diagram

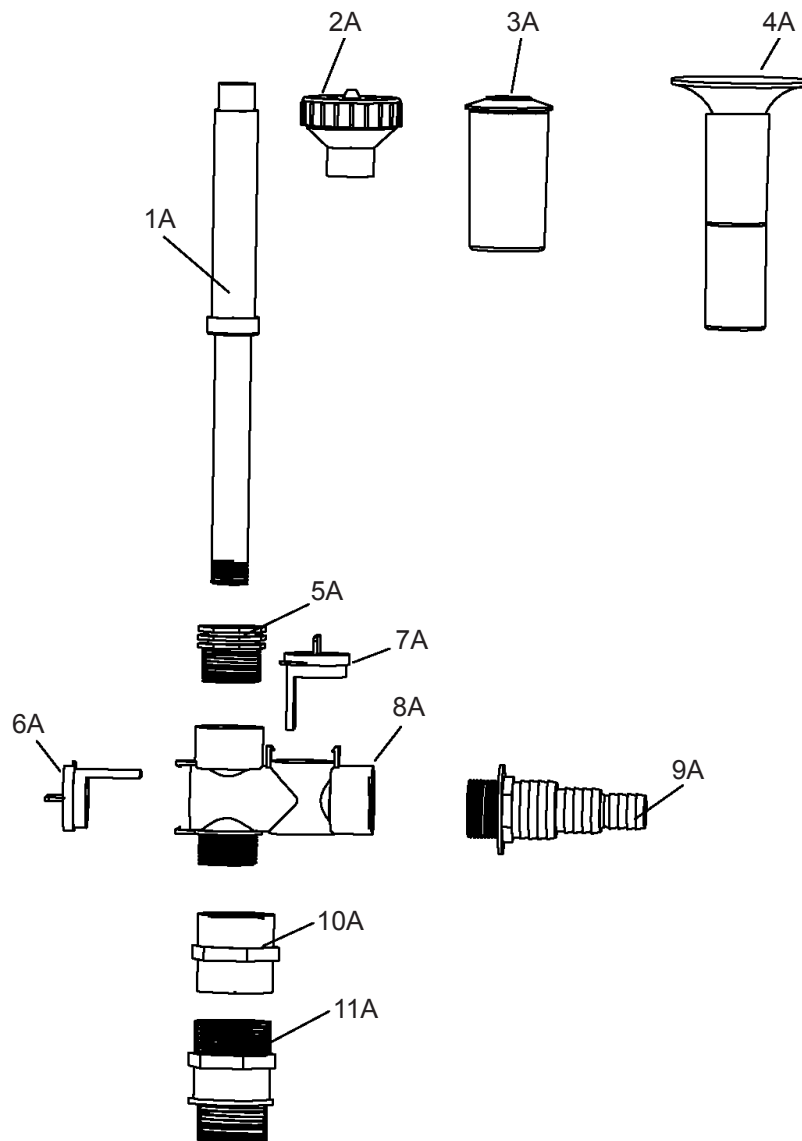

68395 Parts List and Assembly Diagram

Parts List

Part	Description	Qty
1	Front Cover	1
2	Filter	1
3	Water Seating	1
4	Impeller Head	1
5	Impeller	1
6	Impeller Shaft	1
7	Suction Cups	4
8	Water Outlet	1
9	Pump Body	1
10	Motor	2
11	Magnet Wire	2

Part	Description	Qty
12	Power Cord	1
13	Cord Clamp	1
14	String Block	1
15	Back Cover	1
16	Plug	1
17	Suction Cups Holder	1
18	Sealing Ring	1
19	Shaft Cover	1
20	Sealing Ring	1
21	Grounded Terminal	1

Assembly Diagram

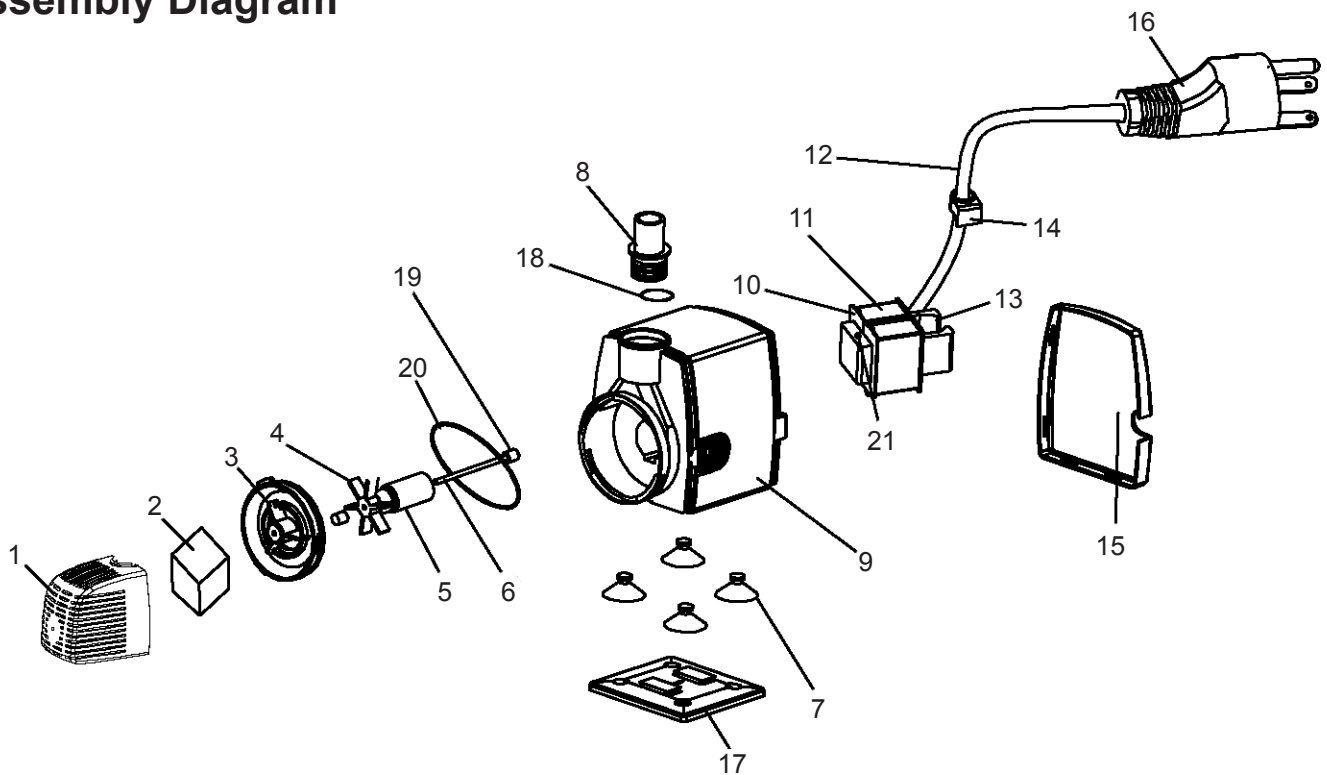

68395 Pump Extension Parts List and Assembly Diagram

Parts List

Part	Description	Qty
1A	Extension	1
2A	Bell Outlet	1
3A	Star Outlet	1
4A	Left Adjustment Lever	1

Part	Description	Qty
5A	Right Adjustment Lever	1
6A	Extension Valve	1
7A	Main Outlet	1
8A	Adapter	1

Assembly Diagram

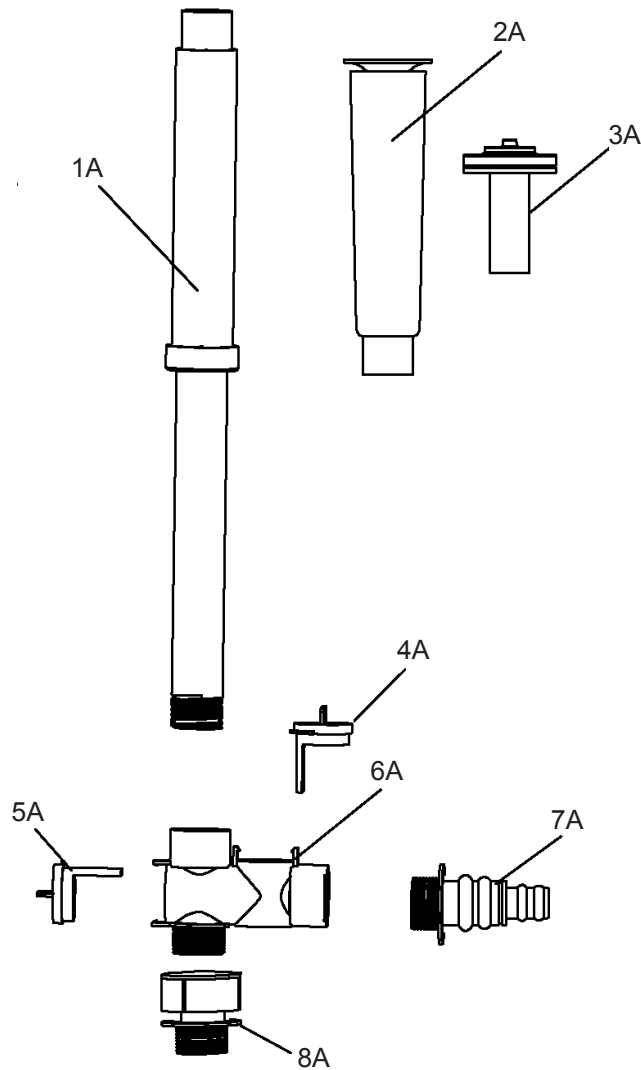

68396 Parts List and Assembly Diagram

Parts List

Part	Description	Qty
1	Front Cover	1
2	Regulator	1
3	Suction Cup	4
4	Water Seating	1
5	Impeller Head	1
6	Impeller	1
7	Impellor Shaft	1
8	Pump Body	1

Part	Description	Qty
9	Motor	2
10	Magnet Wire	2
11	Cord Clamp	1
12	Back Cover	1
13	String Block	1
14	Power Cord	1
15	Plug	1

Assembly Diagram

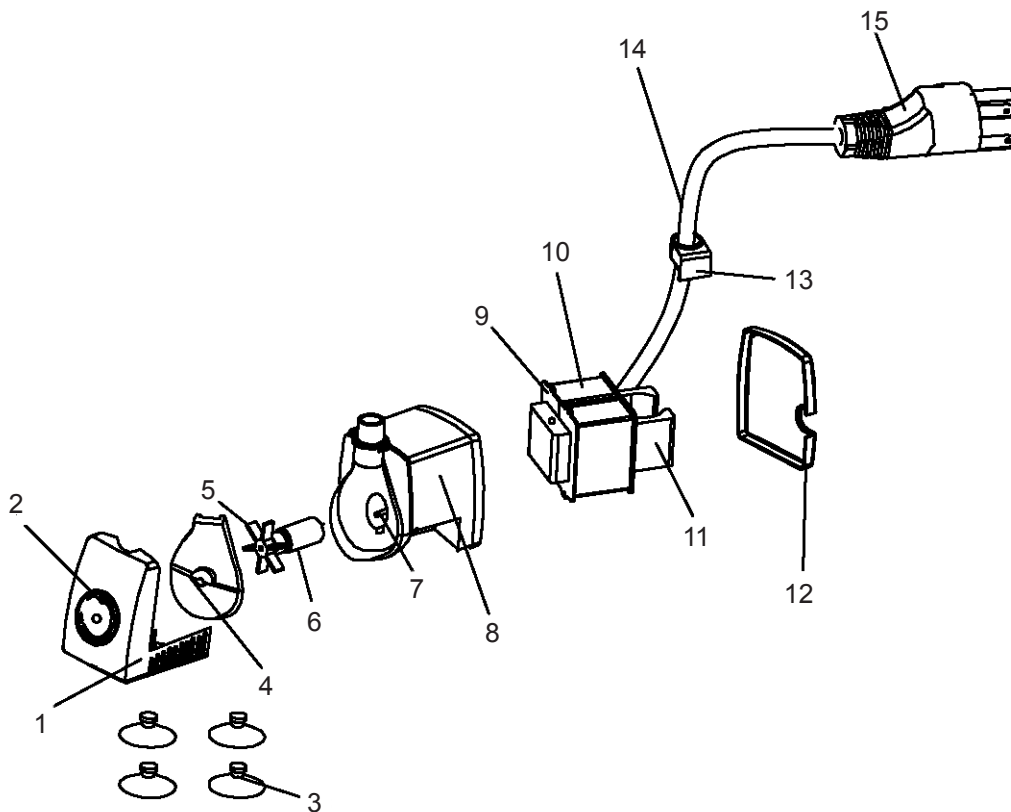

68389 Parts List and Assembly Diagram

Parts List

Part	Description	Qty
1	Regulator	1
2	Front Cover	1
3	Water Seating	4
4	Impeller Head	1
5	Impeller	1
6	Impeller Shaft	1
7	Sealing Ring	1
8	Suction Cup	4
9	Water Outlet	1

Part	Description	Qty
10	Pump Housing	1
11	Motor	2
12	Magnet Wire	2
13	Cord Clamp	1
14	String Block	1
15	Power Cord	1
16	Back Cover	1
17	Plug	1

Assembly Diagram

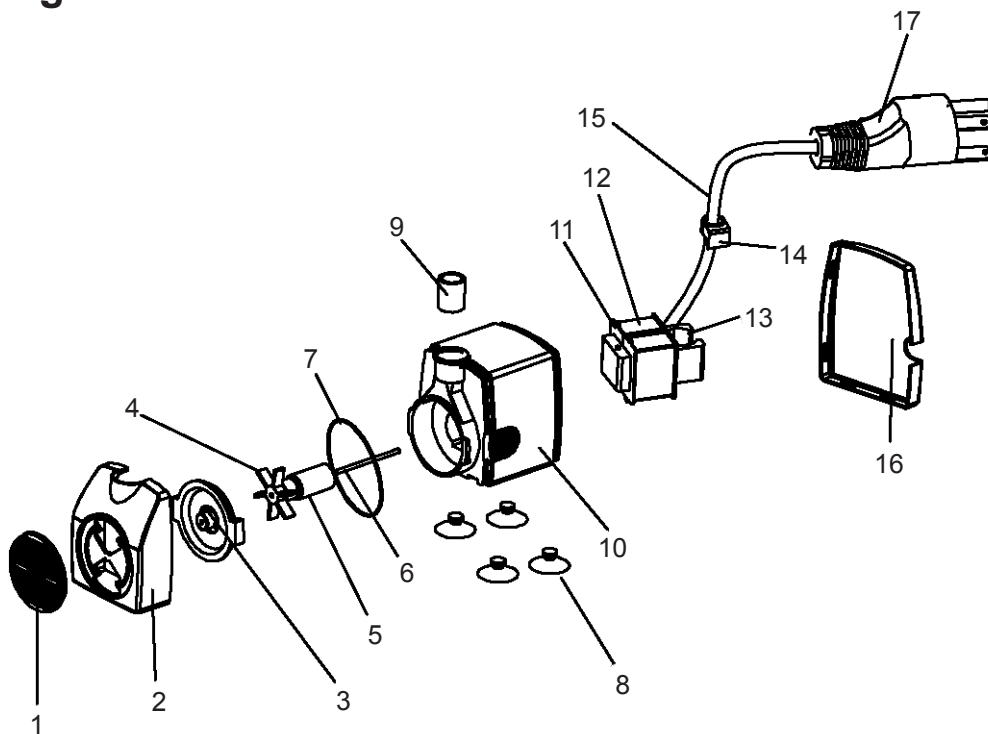

Items 68372, 68393 and 68395: Limited 90 Day Warranty

Harbor Freight Tools Co. makes every effort to assure that its products meet high quality and durability standards, and warrants to the original purchaser that this product is free from defects in materials and workmanship for the period of 90 days from the date of purchase. This warranty does not apply to damage due directly or indirectly, to misuse, abuse, negligence or accidents, repairs or alterations outside our facilities, criminal activity, improper installation, normal wear and tear, or to lack of maintenance. We shall in no event be liable for death, injuries to persons or property, or for incidental, contingent, special or consequential damages arising from the use of our product. Some states do not allow the exclusion or limitation of incidental or consequential damages, so the above limitation of exclusion may not apply to you. THIS WARRANTY IS EXPRESSLY IN LIEU OF ALL OTHER WARRANTIES, EXPRESS OR IMPLIED, INCLUDING THE WARRANTIES OF MERCHANTABILITY AND FITNESS.

To take advantage of this warranty, the product or part must be returned to us with transportation charges prepaid. Proof of purchase date and an explanation of the complaint must accompany the merchandise. If our inspection verifies the defect, we will either repair or replace the product at our election or we may elect to refund the purchase price if we cannot readily and quickly provide you with a replacement. We will return repaired products at our expense, but if we determine there is no defect, or that the defect resulted from causes not within the scope of our warranty, then you must bear the cost of returning the product.

This warranty gives you specific legal rights and you may also have other rights which vary from state to state.

3491 Mission Oaks Blvd. • PO Box 6009 • Camarillo, CA 93011 • (800) 444-3353



3491 Mission Oaks Blvd. • PO Box 6009 • Camarillo, CA 91302 • (800) 444-3353

www.harborfreight.com